

# INNOVATION IN

## Post Office Telecommunications

David Donnelly, CEng., MITP, High Level Designs Ltd, UK



This article provides a personal account of innovation within the ranks of Post Office Telecommunications during the 1970s. It may come as a surprise to many to find that there was any innovation at all outside of the corporation's Dollis

Hill or Martlesham Heath Research Laboratories at that time. However, a few of us were embracing new technology, improving the efficiency of telephone exchange maintenance – and winning a few awards along the way.

**W**ithin the UK in the 1970s, each of the telephone areas inherited from Post Office Telephones<sup>1</sup> had a General Manager of its own. They were largely self governing but united by a common constitution called the Engineering Instructions (later renamed as Telecommunications Instructions), and a stores catalogue known as the Rate Book.

There was a wide range of mechanical, electrical, and electronic equipment in daily use and each telephone area was vexed by its own often

unique mix of problems. Examples include test equipment that was too heavy or large to carry up a staircase, too many or too few alarms being generated, or not being able to make measurements essential to capacity planning at a particular site. Some of these problems could persist for many years because small development projects were given a very low priority by Telecommunications Headquarters (THQ) based in London.

Several Telephone Areas had a special faults investigations (SFI) team. These teams had been formed to recognise and gain experience of the more difficult problems suffered by

Strowger telephone exchanges such as 'Black Spot' - a disease of the electrical bank contacts that required a course of intensive cleaning using yellow and white cotton tapes. During the 1970s, a few of the SFI teams were asked to carry out special projects. These were the projects that were

“ Each Telephone Area was vexed by its own often unique mix of problems ”

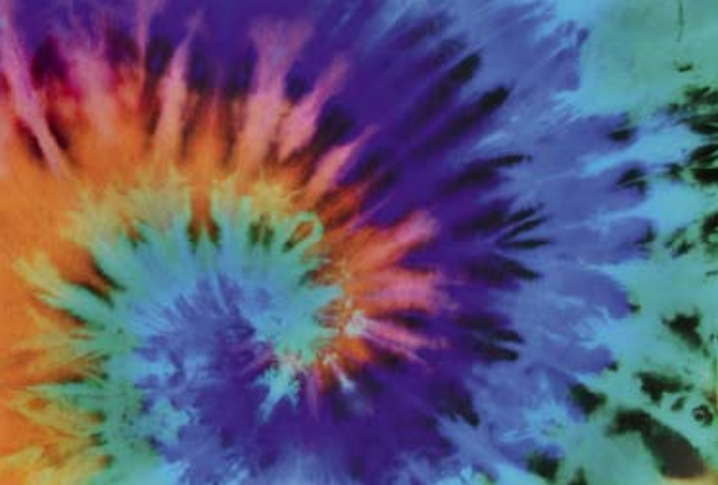

**1970s: A time of tie – dye, flower power and lava lamps. It was also a time of innovation, as David Donnelly, Trainee Technician Apprentice (1972-1975) set out to prove.**

too small for THQ or the corporate research laboratories to care about. However, when I joined Post Office Telecommunications, Manchester South Area, in 1972 as a Trainee Technician Apprentice, I was not aware of this, and I had a reputation to build.

### REPLACING A VALVE

My first ever entry into the national Post Office Telecommunications Awards Suggestion Scheme was to replace the valve in a tester (TRT91) that was essential for dial tone detection. I devised a transistor equivalent for the vacuum tube that had become obsolete. Note that a tester in those days often meant a five foot high rack of equipment, fitted on castors, that could be plugged into the part of the exchange being tested. They were full of relays and made clicking, burping and whirring noises. A row of lamps on the tester would light up in sequence to indicate progress through the test - provided you kept flicking switches to nudge them along. This was an ideal task to assign to a trainee at that time, and it formed a significant part of the day job along with running jumper wires on the main distribution frame.

### A MODEL TELEPHONE EXCHANGE

During my three year apprenticeship, I was trying to grasp how a telephone call progressed through the Strowger director telephone exchange at Sale to which I had been assigned (see Figure 1; page 36). In order to check my understanding, I brought in a model that I'd made to show my colleagues. The model was a small box, about 20cm x 30cm, that had a simple schematic diagram of the telephone exchange on its top surface. Each of the items

shown in the diagram had a tiny light bulb associated with it and there was a small, partially hidden, press button. Pressing the button made the lights come on and go off in a sequence that demonstrated his understanding of how the telephone exchange worked. On seeing this demonstration, my colleagues were shocked to think that all this functionality could be built into one small box. Opening the back of the box revealed that there was actually a lot of space inside. There were no uniselectors or relays. Instead, there was an electronic circuit made from a handful of early 7400 series computer chips (see Figure 2; page 36) that I'd bought from a junk shop in Manchester. My colleagues were also shocked because the realisation soon dawned on them that their days of oiling and adjusting the largely mechanical telephone exchange would be numbered.

### ATTRACTING ATTENTION

I demonstrated the model telephone exchange to the area training officer who in turn brought it to the attention to the head of the power supply division. He was then given a small amount of funding and was allowed to book time on a 'miscellaneous' budget to tackle more widespread problems.

### A DIGITAL RECORDING AMMETER

My first 'miscellaneous' project was for digitally recording bus bar current on punched paper tape. This was being done manually at the time by measuring the height of a graph on a pen recorder and then sitting at a teletype terminal to key in the values by hand. A remote mainframe computer could then calculate the area under

the graph, and compute the power consumption that, for an electro-mechanical exchange, was proportional to the overall volume of telephone traffic. Due to the tiny budget available, the digital circuitry had to be built into a standard yellow tool box. I incorporated an early digital voltmeter circuit that was connected to the large bus bar shunt in place of a pen recorder. Each current measurement, punched as a series of holes into the tape, required an accompanying time stamp, and so I designed and constructed one of the first ever digital clocks and built that into the lid of the tool box. All this was achieved using nothing more than 7400 series logic gates and operational amplifiers. I was given a printing re-perforator (an 8-hole-wide paper tape punching machine) but had to devise a way to drive the 70-volt solenoids to actually punch the tape. I chose high speed relays for that task.

### CHOPPER AMPLIFIER

Next, I discovered that not all exchanges had a suitable bus bar shunt to which a recording ammeter could be connected. Amazingly, it had been standard practice in these exchanges to fit a shunt alongside a section of bus bar, saw through the bar, take the measurements over a few weeks, then weld the original bar back together and remove the shunt. To solve this problem, I independently invented the chopper amplifier<sup>2</sup> for measuring micro-volt potential differences in a standard length of aluminium bar. I once again chose a high speed relay, this time to chop the minute volt drop into a square wave that could be amplified more accurately. The square wave a.c. signal was amplified, precision rectified, and smoothed back

to d.c. for output to the pen recorder using three 741 series operational amplifier chips. This project was highly successful. I made a few of these devices and used them at several exchanges around Manchester South Area. In addition, with three connections attached to a length of bus bar, around the point where a cable was bolted on, the device was able to solve a simple equation to determine the amount of current leaving the bar and into the cable.

### FIRST TELEPHONE CALL DISTRIBUTOR

By now I'd become well known with all the divisional heads in Manchester South Area, and was asked to devise a way of steering telephone calls to the engineers who dealt with calls to the repair service control centre based at Altrincham. The idea was to steer calls from 20 incoming telephone lines to the engineer most likely to be seated next to the carousel holding the routing and record cards relating to the telephone exchange from which the customer was calling. This was achieved by making an electronic switching system out of 7400 series logic gates and reed relays. Several of these devices were slotted in a card cage that was put on top of the old manual board used by the engineers. The beauty of this design was in the fact that it automatically distributed calls, giving priority to the engineers sat next to the information they needed, but could also send calls to those engineers a little further up the room if they were free. It no longer relied on a human to remember which call had been waiting the longest.

### OSCILLOSCOPE BEAM SPLITTER

After my apprenticeship I was given the rank of technician and, whilst still based at Sale telephone exchange, I independently invented an oscilloscope beam splitter<sup>3</sup>. Having two traces on the display helped with fault finding on the discrete diode transistor logic circuitry of the newly introduced Stored Programme Control (SPC) unit that had replaced the electro-mechanical directors in the core of the exchange (see Figure 3). I built the circuitry into a small

cough drop tin. The beam splitter worked by separately modulating the top and bottom of a high frequency square wave.

### JOINING THE SFI TEAM

I was soon promoted to Technical Officer and transferred to the local SFI team (see Figure 4) which was then based at Gatley telephone exchange in Cheadle. There, I helped the team to develop a variety of alarm managers and test equipment for manual boards, crossbar, and reed relay electronic telephone exchanges. The team was made up of several very talented individuals. My first project with the SFI team involved splitting an existing tester into three separate

boxes, redesigning the circuitry to use miniature relays and light emitting diodes, and to make each box truly portable. Now, not only could three people work on these tests independently, but they no longer had to risk injury carrying the original tester up a winding staircase!

### TXE4 ALARM MANAGEMENT

A TXE4 reed relay electronic telephone exchange had a lot of built in redundancy to provide resilience. It could tolerate large parts of it being taken out of service without affecting customers. Despite this, it was very trigger-happy and would set alarms off in the middle of the night resulting in engineers being called out who



Callers were getting a lot of wrong numbers and the technical officers on exchange maintenance could not get the 'A' relays (that detected loop-disconnect dialling pulses) to consistently pass overnight test routines. A little investigation revealed that the circuitry around the 'A' relays, and also their associated test equipment, both suffered from similar design flaws.

only had to press a reset button and go home. The engineers explained that the exchange need only generate a call-out when five out of nine groups of alarms had been raised and within each group there had to be at least two out of three alarms raised. My first thought was to solve this problem using logic gates but, after a little more consideration, a much simpler solution emerged. I revamped an old analogue computing technique that utilised appropriately weighted resistors, a few diodes, and one transistor. I also remember replacing an error counter that used discrete transistors to divide-by-8 with a 7400 series counter chip configured to divide-by-128. Both solutions were rolled out across the telephone area and made Manchester South's call-out figures look brilliant when compared to the national average.

### **FIXING CROSSBAR EXCHANGES**

The newly installed TXK3 crossbar exchanges presented an interesting challenge. Callers were getting a lot of wrong numbers and the technical officers on exchange maintenance could not get the 'A' relays (that detected loop-disconnect dialling pulses) to consistently pass overnight test routines. A little investigation revealed that the circuitry around the 'A' relays, and also their associated test equipment, both suffered from similar design flaws. When looking at the circuitry, it was found that only one contact of the 'A' relay was being used and its pulses were intended to be 'cleaned up' by two discrete transistor mono-stables that were hand-wired onto soldered connection strips. The problem was that these mono-stables were stretching any contact bounce and making it worse, rather than removing it. The solution was simply to make full use of the changeover contact on the 'A' relay and re-wire the circuitry as a single bi-stable. This worked perfectly on one exchange but before it could be rolled out further, a much more expensive national solution was put in place. That involved replacing the armature of every 'A' relay with a Hall Effect Device<sup>4</sup> together with related electronics to amplify the signal!

### **ENTER THE MICROPROCESSOR**

My first microprocessor development system was an SC/MP Introkit<sup>5</sup> based on an INS600D microprocessor from the National Semiconductor<sup>®</sup> Corporation<sup>6</sup>. This introductory kit made use of the keyboard and display of a hand-held calculator attached by a ribbon cable to the main circuit board. When I brought the kit into work, I was able to show that it could monitor meter pulse supplies from telephone exchanges all around the Telephone Area over a number of private wires. At that time, the meter pulses were derived from a pendulum clock in each exchange, and the pulse rate (cheap, medium, full) was selected manually by a local technician three times a day. By monitoring all the supplies and forming a majority decision as to what the tariff rate should be, the micro-processor was able to raise an alarm if any meter pulse supply was either too late or too early changing over to the next rate.

### **TRAFFIC PATTERN MEASUREMENT**

Around 1978 most telephone areas had to clear some central office space for a DEC<sup>7</sup> PDP11 mini-computer that was used to remotely generate test calls originating from each local exchange and accurately measure Quality of Service for the first time. The problem with this was that the statistical distribution of the test calls and their destinations had to approximate that of real telephone subscribers. Gathering the necessary real traffic distribution pattern, by hand, took one person about a month spread over a six month period for each local exchange. To help out with this activity, I devised a microprocessor solution that could monitor the digits being dialled into the 'A' digit selectors of Strowger exchanges and analyse the area codes of 3000 real telephone calls in just three days elapsed time. One rather curious point of design detail was when I described this solution as a box that had one input (i.e. 10 pulses per second loop disconnect dial pulses in), and one output (10 pulses per second loop disconnect dial pulses out). The output was loop disconnect only

because that was the interface to the cheapest printer available from the Rate Book (a Printer 302) that I used to print a table of the most frequently observed area codes and their corresponding call counts. Despite this solution working extremely well, and being used all over Manchester South, it failed to win a national suggestion award because the judges felt that it gathered the data too fast. They had completely overlooked the fact that the measurements could be repeated as often as necessary over a six month period and within days of a new trading estate opening up for example.

### **RANDOM CALL GENERATOR**

Towards the end of the 1970s, the TXE4 reed relay exchange roll-out programme was accelerating. To support the process of installation and acceptance testing, flood test equipment was needed to exercise each exchange before it was brought into service. However, commercial flood test equipment was very cumbersome and expensive. What was really needed was something that could simply generate thousands of calls to random destinations within the new exchange. The random telephone calls could make it look like the exchange was already in service, tease out any equipment alarms, and compete with the relatively small amount of genuine test traffic that could be arranged for. My microprocessor solution, based on an Intel<sup>®</sup> 8085 chip, was cabled up to 96 incoming trunk circuits and was able to generate 9600 calls an hour. Interestingly, it used so many random numbers that repeating patterns were often discovered after about one week of operation. To combat that problem, I developed a white noise source, with an associated high speed counter that could be read by the microprocessor whenever it needed a random number. The team made several of these random call generators and hired them out to other Telephone Areas.

### **THE EDGELEY ELECTRONIC QUEUING EQUIPMENT**

The head of maintenance for Manchester South Telephone Area had a problem with the maintainability of the electro-mechanical call queu-

ing system used by directory enquiries operators based at Edgeley near Manchester. The wear and tear on uniselectors was unacceptable<sup>8</sup>. Both the uniselectors and their associated wiring looms had to be constantly replaced [1].

I was able to recommend, design, and build a replacement system (see Figure 5) using:

- A Commodore PET<sup>9</sup> computer (shown in Figure 4), brought in from home;
- An Intel 8085 microprocessor development system;
- State machine solutions, learned while maintaining the SPC telephone exchange equipment;
- Reed relay technology from TXE4 building blocks.

That system was the first queuing system to use a personal computer purely as a management interface and was also the first system to automatically manage the length of a queue with respect to the number of agents in service. It was so successful that representatives of Birmingham Factories Division (which later became Fulcrum Communications Ltd.) came to see the small SFI team in Manchester and began mass producing these systems for national roll-out. As a result of this the team won the largest ever Suggestion Award up to that date of £12,000 [2].

## A WHITE METER PROJECT

The last project that I completed for Manchester South Telephone Area was to develop a 'white meter' solution. The management team were toying with the idea of providing discounts for multi-national business users or for calls that people made to their circle of family and friends. I often think of this as my finest piece of design work but it had to be kept very quiet at the time because it might have been considered anti-competitive. The team made several devices each capable of monitoring 16 telephone lines and switching their meter pulses to cheaper 'white meters'. This design had a few novel features including a hand held display. The display unit looked like a TV remote control but it worked in reverse, with the rack mounted equipment beaming an infra-red signal to the hand held device.



Figure 1

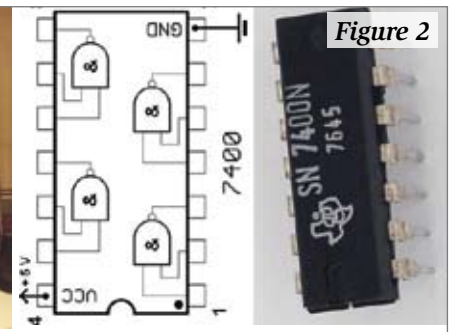

Figure 2



Figure 3



Figure 4

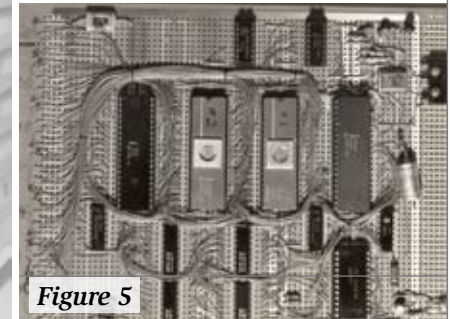

Figure 5

**Figure 1:** People that could be found most days working at the 30,000 line exchange in Sale, Cheshire, around 1977. It includes both maintenance and exchange installation people together with one member of the SFI team and two cleaners. (The author is front row, far right). Image Copyright © David Donnelly 1977

**Figure 2:** An example of a 7400 series integrated circuit. They were used to build the mini and mainframe computers of the 1960s and 1970s and pin-compatible descendants of the original family have since become de-facto standard components.

**Figure 3:** The author at the control panel of a GEC Mark 1c Telecommunications Computer. Five double racks of this stored program control equipment replaced the director heart of two of the 10,000-line Strowger exchanges at Sale. The Diamond Ring Stores have been turned to face the camera. The stored program was created by threading wires vertically through rows of horizontal transformers. A similar store mounted on the back of the rack provided local number translations for both local and national dialling codes. This image first appeared in the Sale version of The Messenger newspaper on 25 February 1977 and is used with permission. Image Copyright © David Donnelly 1977

**Figure 4:** Six members of the SFI team and a Commodore PET computer. From the left: John Harris, Charlie Heald, Colin Price, Peter Gibbons, David Donnelly (the author), and Jim Hirst. (May 6, 1983; Copyright © Manchester Evening News.)

**Figure 5:** My first self contained micro-computer card. The key features of this card are the 8085 microprocessor chip, which ran at a clock speed of just 3MHz (half the crystal frequency), 4kbyte of Erasable Programmable Read Only Memory chips, and just over 2kbyte of Random Access Memory. When used within the Edgeley call queuing equipment, this card could control up to 48 incoming telephone calls and connect them with 20-agent consoles whilst gathering raw statistics for further interpretation and display by a Commodore PET computer. (Image Copyright © David Donnelly 1982.)

## PAST, PRESENT AND FUTURE

**Past:** Back in 1977, I was named Apprentice of the Year after winning both a regional heat and a national final competition held over a 4-day period at the Post Office Telecommunications Training Centre at Stone [3]. The prize for winning that title was to represent the UK for Industrial Electronics in the International Apprentice Competition held in Utrecht later that year. The Society for the Promotion of Vocational Training and Education (VOTE) organised the international contests which began in 1950 and covered a wide range of skills from car maintenance to brick laying.

Life was different in the 1970s because most site-specific problems were hardware-related and not software-based. I was a subscriber to the magazine Practical Electronics from the late 1960s where I learned about 7400 series logic chips one by one as they came onto the UK hobbyist market for the first time [4]. I also learned analogue computing techniques [5] and built several electronic projects at home. With this knowledge and practical experience, I was positioned well ahead of the game when I started my apprenticeship in 1972.

**Present:** Today, there is more emphasis on configurable software-based applications and services and the balance between the network

operator and equipment suppliers has changed. There are far fewer opportunities for field modifications to modern IT-based telecommunications equipment.

Operators now outsource much of the design, build, fault and repair work to their suppliers and suppliers are expected to continuously upgrade and improve their own products.

**The future:** Today's telecommunications companies should never lose sight of the fact that their own people are often capable of suggesting improvements to modern systems and services. But how can we encourage today's apprentices and technicians to be creative and think outside of the box? How can we trust the brightest ones to use some 'miscellaneous budget' wisely when we are all so tightly time-managed these days?

I am pleased to see that the ITP continues to run a national Apprentice Awards scheme to this day. The national Apprenticeship Awards are held annually to celebrate the success of apprentices who have made a real difference to their future and to the organisation they work for. They also recognise the work of employers who are successfully tackling skills shortages to build their future workforce through apprenticeships.

In addition to apprenticeship

“ I am pleased to see that the ITP continues to run a national Apprentice Awards to this day. ”

schemes and especially in these times where cash incentives for engineers may be limited, perhaps we should also be thinking of rewarding our best people by giving them some quality time to try out new ideas of their own, and trusting them to innovate. For example, certain innovative animation studios and search engine companies are often cited as model businesses where employees are encouraged to spend a portion of their time each week working on personal projects.

Employee suggestions should always be encouraged, properly rewarded, given serious consideration and whenever possible, they should be further developed and rolled out nationally or even internationally.

For any engineer the best prize of all is seeing their ideas being adopted by the company, making significant cost savings, or bringing in new business.

## AUTHOR'S CONCLUSIONS

I believe I was extremely fortunate to have been working in the right place at the right time in history, and to have been given flexibility by my managers to try different things. During the 1970s, many telecommunications engineers had electronics as a hobby and their expertise could be put to good use both at home and at work to solve common problems using a combination of discrete electronics and logic gates.

In those days, maintenance technicians had to have full visibility of the circuit diagrams they were supporting and electro-mechanical systems such as telephone exchanges could be greatly improved by adding a small amount of electronics.

Once you had become known for this kind of

innovation, there would always be some 'miscellaneous budget' that could be used by your line management to fund local projects that could make their department or region look better than the national average for quality of service, productivity or efficiency<sup>10</sup>.

Throughout the 1970s, there was a flourishing Award Suggestion Scheme within Post Office Telecommunications and a number of field solutions were also published in the regular "Regional Notes" section of the IBTE Journal (*the predecessor of the ITP Journal*). However, most telephone areas kept their ideas to themselves unless they actually won a significant award. Therefore, other areas could well have a similar story of local innovation still to tell.

## References

1. Donnelly, D.R., and Hirst, R.J. The Edgeley Electronic Queueing Equipment. The Journal of The Institution of British Telecommunications Engineers Vol 1 Part 3 p155 October 1982
2. "Record award for the queue beaters", BT staff newspaper "Telecom Today", June, 1983, Page 16.
3. James, A. (reporter). "David could win apprentice Olympics". The Sale and Altrincham Messenger group of newspapers. 25 February 1977
4. Microelectronics. Practical Electronics, 1967.
5. P.E. Analogue computer. Practical Electronics, 1968.
6. Ainslie, A.C. 8-channel logic trace multiplier. Practical Electronics, Vol 11 No. 8 August 1975.

## ABBREVIATIONS

SFI	Special Faults Investigations
SPC	Stored Programme Control
THQ	Telecommunications Headquarters

## FOOTNOTES

- <sup>1</sup> In October of 1969, the General Post Office ceased to be a government department and the Post Office Telephones division was renamed Post Office Telecommunications. Post Office Telecommunications was eventually renamed to British Telecom in 1980 in anticipation of the British Telecommunications Act of 1981.
- <sup>2</sup> Chopper amplifiers employing vibrating metal contacts and valve amplifiers had been around since the 1950s and were used for medical and scientific purposes. Analog Devices™, Inc., based at Norwood, Massachusetts, launched its first chopper amplifier based on a Field Effect Transistor switch in the late 1960s. They were in modular form, about 2.5cm square, with components soldered onto a small board that was then cast in epoxy resin.
- <sup>3</sup> The author wrote up his solution and sent it to Practical Electronics magazine. However, he was advised that the magazine had just taken receipt of an 8-trace design from another contributor [6].
- <sup>4</sup> See [en.wikipedia.org/wiki/Hall\\_effect](http://en.wikipedia.org/wiki/Hall_effect)
- <sup>5</sup> See [www.old-computers.com/museum/computer.asp?st=1&c=1147](http://www.old-computers.com/museum/computer.asp?st=1&c=1147)
- <sup>6</sup> National Semiconductor Corporation is based at Santa Clara, California.
- <sup>7</sup> Digital Equipment Corporation that was based at Maynard, Massachusetts.
- <sup>8</sup> The uniselectors in question were known as primary and secondary 'allotters'. They belonged to the Southampton Suite, so named because the design was first installed in the Southampton Telephone Area. In trying to cope with almost 10,000 calls a day, the engineers at Edgeley were having to adjust or change several sets of wipers a day, replace a set of bank contacts once a week, and the whole wiring loom for a shelf every couple of months. The air was thick with the smell of hot flux from all the soldering that was required.
- <sup>9</sup> See [www.old-computers.com/museum/computer.asp?c=103&st=1](http://www.old-computers.com/museum/computer.asp?c=103&st=1)
- <sup>10</sup> The rivalry between telephone areas even extended to the choice of hard hat. The so called 'Manchester Type' helmet allowed rain water to drip down the back of your neck, whilst the 'Liverpool Type' had a gully that channelled water around to the front where it would periodically run off the peak when you bowed your head.

## ABOUT THE AUTHOR

DAVID DONNELLY



**David Donnelly** joined Post Office Telecommunications in 1972. He studied for his Bachelor's degree at Manchester Polytechnic. His final year project involved tracking a moving object using ultrasound. In 1983, he won the IBTE 'Fudge' Trophy which was then awarded for System Design. After leaving Manchester South Telephone Area, he spent 7 years with Birmingham Factories Division developing the Edgeley, QUERC, and CMS100 call queuing systems. He transferred to BT Laboratories at Adastral Park in 1990 and obtained a Masters degree in Telecommunications in 1997 from the University of London. In April 2008, he set up his own company "High Level Designs Ltd.". Since then he has developed a collaborative design software application known as "Solution Designer" and published a book entitled "Designing in a Big Way - a practical guide for managers" ISBN: 978-0-9562164-0-3. Earlier in 2010, David was successfully awarded Chartered Engineer status as a direct result of the ITP-IET member registration programme.